



Easily Weigh Fresh Proteins

- Boneless, Bone-In, Marinated

Integrate With Triangle VFFS

- Automatically produce gas flushed packaging for extended shelf life. Under 1% achievable
- Direct replacement for vacuum pack flip-flops
- World's only bagger/scale combination controlled by Rockwell Automation's ControlLogix

Fully Automate Your Packaging Line

- Reduce labor up to 80% on each line
- Capability to double your production



Triangle Fresh Protein Weigher

Fresh Poultry Packaging System Specifications

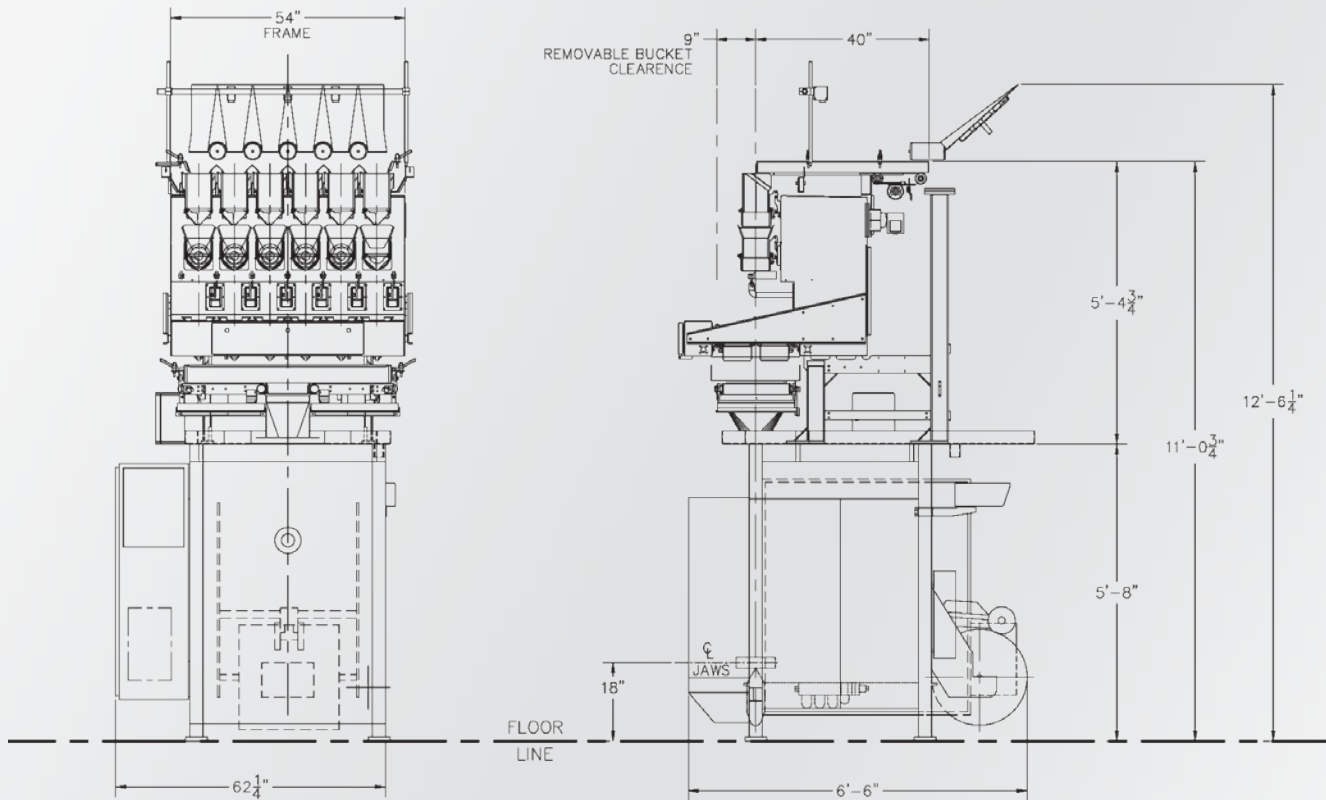

Bag Size Range (XY)

Min: 2.5" W x 15" L

Max: 15" W x 20" L

Machine Construction

USDA baggers include 304/EP/SS frame
100% sanitizable

Available in Nema, Nema 4X and 6P
Sealed Cabinets w/ Dryers

Speeds

Poly to 80 BPM; Supported to 75 BPM

Controls

Standard Rockwell Automation's ControlLogix
Custom programming available

Utilities

Power: 208/230/480V, 30A, 1-phase standard
15A draw
Air: 80 PSI, 5 CFM



Service

22 Service Technicians
14 Years Average Tenure

Training

FAT at Triangle before shipment
Custom Training Programs

Bag Styles:

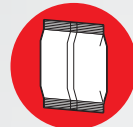

PILLOW



GUSSET



FLAT
BOTTOM



4-CORNER
STAND-UP



6655 West Diversey Avenue
Chicago, Illinois 60707
800.621.4170 • info@trianglepackage.com
www.trianglepackage.com